

Servel

by Dometic

INSTALLATION AND OPERATING INSTRUCTIONS

REFRIGERATOR FOR LP-GAS AND ELECTRIC OPERATION.

Model RGE400

Contents:

	Page
Installation	2
Operating Instructions	3
Maintenance & Service	5

FOR YOUR SAFETY

If you smell gas:

1. Open windows.
2. Don't touch electrical switches.
3. Extinguish any open flame.
4. Immediately call your gas supplier.

FOR YOUR SAFETY

Do not store or use gasoline or other flammable vapors and liquids in the vicinity of this or any other appliance.

WARNING: Improper installation, adjustment, alteration, service or maintenance can cause injury or property damage. Refer to this manual. For assistance or additional information consult a qualified installer, service agency or the gas supplier.



AVIS

Cet appareil doit être réparé seulement par un réparateur autorisé. Modification de l'appareil pourrait être extrêmement dangereuse, et pourrait causer mal ou mort.

RECORD THIS INFORMATION FOR FUTURE REFERENCE BEFORE INSTALLING THE UNIT:

Model No. Serial No.
 Product No.
 Date Purchased
 Place of Purchase

Corporate Office
2320 Industrial Parkway Elkhart, IN 46515

USA
 Service Office
 The Dometic Corporation
 509 South Poplar Street
 LaGrange, IN 46761
 Phone: 219-463-4858

For Service Center Assistance
 Call: 800-544-4881

CANADA
 Dometic Distribution Inc.
 866 Langs Drive
 Cambridge, Ontario
 N3H 2N7 Canada
 Phone: 519-653-4390

800-70-50-00

INSTALLATION

GENERAL INSTRUCTION

This appliance is designed for storage of foods and storage of frozen foods and making ice.

The refrigerator outlined herein have been design certified by A.G.A. under the ANSI Z21.19 Refrigerator Standard, for a free-standing installation and is also approved by the Canadian Gas Association.

The certifications are, however contingent on the installation being made in accordance with the following instructions as applicable.

In the U.S.A., the installation must conform with:

1. National Fuel Gas Code ANSI Z223.1 -(latest edition)
2. Manufactured Home Construction and Safety Standard, Title 24 CFR, Part 3280.
3. Any applicable local code.

The unit must be electrically grounded in accordance with the National Electric Code ANSI/NFPA 70-(latest edition) when installed, if an external alternating current electrical source is utilized.

In CANADA, the installation must conform with:

1. Current CAN/CGA 8149 **Gas** Installation Codes
2. Where a flexible metal connector is used, it must comply with the provisions of the current Standard CAN1-6.10, METAL CONNECTORS FOR GAS APPLIANCES.
3. Any applicable local code

The unit must be electrically grounded in accordance with the current CANADIAN ELECTRICAL CODE C22 Parts 1 and 2.

FREE-STANDING MODEL FOR FLOOR INSTALLATION ONLY

The room must be well ventilated and not used as a bedroom.

Further the room should have a window (which can be opened) or a door to the outside.

For best performance also at high ambient temperatures there must be a free air circulation over the cooling unit at the rear of the refrigerator.

Ensure that there is a free space of at least 4 inches (100 mm) above the refrigerator and that the ventilation opening on the top of the cabinet is not covered in any way. Do not place the refrigerator in a space where air circulation is restricted.

A clearance of at least 1 inch (25 mm) should be left between the rear and sides of the refrigerator and the surrounding walls.

This free-standing refrigerator requires accessibility to the back for servicing the gas equipment. If allowed by the Local Authorities, the accessibility can be obtained by using a certified Flexible Metal Connector of Gas Hose Assembly which would allow the refrigerator to be withdrawn without disrupting the gas supply.

However, if the Local Authorities require a rigid **gas** supply connector the refrigerator should be located with sufficient space at the back for servicing or, if located

against a wall, a removable panel of a minimum size of 16" x 20" should be provided in the wall to allow access to the rear of the refrigerator.

The refrigerator must be adjusted to a vertical position in both directions.

Use the feet on the refrigerator to adjust its position.

CLEARANCES

Minimum clearances in inches to combustible materials are:

Top	4"
Side	1"
Rear	1"

Bottom the feet must be in place to ensure free air circulation.

See Figs. 1 & 2.

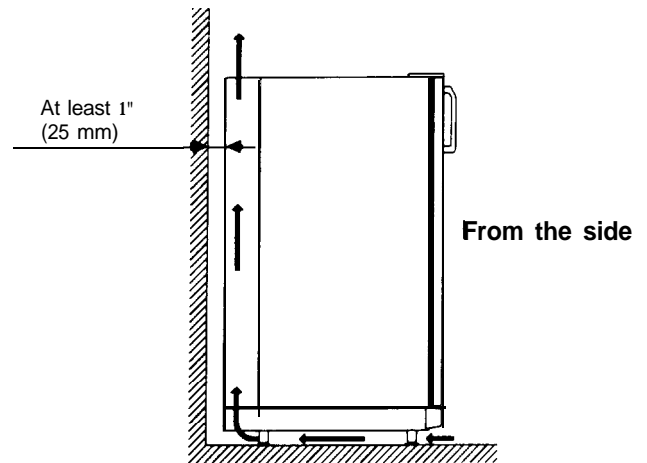

FIG. 1

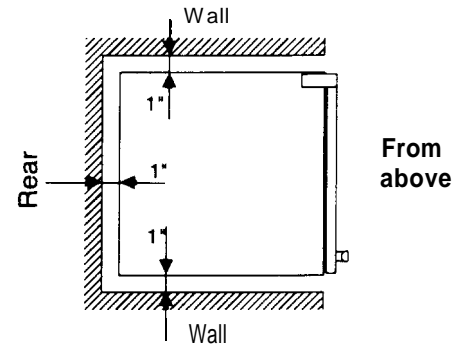

FIG. 2.

NOTE: DO NOT install the appliance directly on carpeting. Carpeting must be removed or protected by a metal or wood panel beneath the appliance, which extends at least the full width and depth of the appliance.

GAS CONNECTION

Hook-up to the gas supply line is accomplished at the manual gas shutoff valve, which is furnished with a 3/8" SAE (UNF 5/8" -18) male flare connection. **A backup wrench must be used when tightening gas supply fitting.** All completed connections should be checked for leaks with a noncorrosive leak detector.

! WARNING

DO NOT use a flame to check for gas leaks.

The gas supply system must incorporate a pressure regulator to maintain a supply pressure of not more than 11 inches water column.

When testing the gas supply system at test pressures in excess of 1/2 psig, the refrigerator and its individual shutoff valve must be disconnected from the gas supply piping system.

When testing the gas supply system at pressures less than or equal to 1/2 psig, the appliance must be isolated from the gas supply piping system by closing its individual manual shutoff valve.

In case detailed instructions on the installation and connection to the gas supply are required, contact your dealer or distributor.

TESTING LP GAS SAFETY SHUTOFF

The gas safety shut-off must be tested after the refrigerator is connected to the LP gas supply.

To test the gas safety shut-off, proceed as follows:

1. Start the refrigerator according to the instructions for Gas Operation, section "Operation Instructions".
2. Check that the gas flame is lit. This can be observed through the reflector (E).
3. **Close** the gas valve by turning the knob (A) back to "OFF" position.
4. Wait for one minute.
5. Remove burner cover plate, one screw at the burner. Open the gas valve by turning the knob (A) to position "GAS" without pushing the buttons (C) and (D). Apply a non-corrosive commercial bubble solution to the burner jet.
6. No bubbles should appear at the opening of the burner jet. The presence of bubbles indicates a defective gas safety shutoff, and service is required.
7. If no bubbles were present at the burner jet, the gas safety valve is working properly. Rinse jet thoroughly with fresh water before proceeding. Be careful not to damage the burner jet. Replace burner cover plate and turn the knob (A) back to "OFF". Start the refrigerator by following the instructions for Gas Operation, section "Operation Instructions". Normal operation of the burner should return. Allow the burner to operate for a minimum of 5 minutes.

ELECTRICAL CONNECTION

120 Volt AC Connection

The refrigerator is equipped with a three-prong (grounding) plug for your protection against shock hazards and should be plugged directly into a properly grounded three-prong receptacle. **DO NOT** cut or remove the grounding prong from this plug. The cord should be routed to avoid direct contact with the burner cover, flue cover or any other components that could damage the cord insulation.

OPERATING INSTRUCTIONS

IMPORTANCE OF LEVELING A REFRIGERATOR

In an absorption refrigerator system, ammonia is liquefied in the finned condenser coil at the top rear of the refrigerator. The liquid ammonia then flows into the evaporator (inside the freezer section) and is exposed to a circulating flow of hydrogen gas, which causes the ammonia to evaporate, creating a cold condition in the freezer.

When starting this refrigerator for the very first time, the cooling cycle may require up to four hours of running time before the cooling unit is fully operational.

The tubing in the evaporator section is specifically sloped to provide a continuous movement of liquid ammonia, flowing downward by gravity through this section. If the refrigerator is operated when it is not level, liquid ammonia will accumulate in sections of the evaporator tubing. This will slow the circulation of hydrogen and ammonia gas, or in severe cases, completely block it, resulting in a loss of cooling.

The refrigerator must be adjusted to a vertical position in both directions.

Use the feet on the refrigerator to adjust its position.

CONTROLS

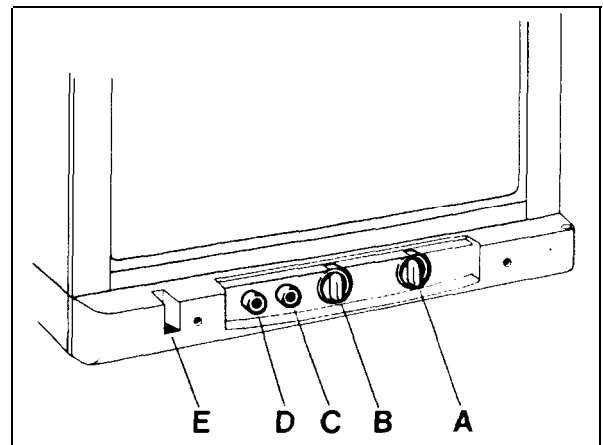

FIG.3.

The refrigerator can be run on either 120 volt AC or LP gas. Changing between these modes of operation is carried out by means of control buttons positioned as shown in fig. 3.

The energy selector (A) can be set at either "ELEC" (120 volt AC), "GAS" (LP gas) or "OFF".

The refrigerator temperature is controlled by a thermostat (6). Please note that the thermostat has no "off" position.

The refrigerator is fitted with a safety device which automatically shuts off the supply of gas if the flame goes out. The safety device can be opened manually by depressing knob (C).

The piezoelectric igniter discharges sparks over the burner when the button (D) is pushed.

In the flame viewer (E) you can see a blue light when the flame is alight.

GAS OPERATION

The position numbers refers to FIG. 3.

1. To start the refrigerator, turn the knob "A" to the "GAS" position.
2. Turn the thermostat knob "B" to setting 4.
3. Push button "C" to stop - and hold, push button "D" for the piezo igniter several times to light the burner. This can be observed through the flame view port "E".
4. After the flame lights, continue to hold the button "C" for an additional ten (10) seconds. Release the button "C" and check the flame view port "E" to make sure the burner does not go out. If the burner goes out, repeat the lighting procedure Steps 1 through 4.
5. To shut off the refrigerator, turn the knob "A" to the "OFF" position.

NOTE: After changing an LP tank, or after a long shut off period, the gas line is likely to be filled with air. You may have to repeat the lighting procedure several times to purge the air out of the gas lines.

ELECTRIC OPERATION

The position numbers refers to FIG. 3.

1. Check to be sure the power cord is properly connected to the power supply.
2. Turn knob "A" to the position marked "ELEC" for 120 volt AC operation.
3. Turn the thermostat knob "B" to setting 4.
4. To shut off the refrigerator, turn the knob "A" to the "OFF" position.

THERMOSTAT

The refrigerator is equipped with a thermostat that can be adjusted by turning knob "B" to different setting to maintain the desired cabinet temperature. See FIG. 3.

1. **"OFF" Setting of the Thermostat:** In gas operation, the thermostat closes its main valve and the burner runs continuously at the bypass rate or pilot. In electric operation, the contacts in the thermostat are open and the heating element is off.
2. **"MAX" Setting of the Thermostat:** In gas operation, the thermostat allows the burner to remain on high flame continuously. In electric operation, the heating element is "ON" continuously.
3. The thermostat can be adjusted between "MAX" and "OFF" to obtain the desired cabinet temperature. The closer the knob is to "MAX", the colder the cabinet temperature. The closer the knob is to "OFF", the warmer the cabinet temperature.

When the thermostat reaches the set temperature, it will cut the burner back to bypass or, in electric operation, shut off the heating element.

The setting of the thermostat is not critical, but we recommend it be adjusted to maintain a dry frost on the cooling fins. Adjust the thermostat knob closer to "MAX" when the outside temperature becomes warm.

HOW TO USE THE REFRIGERATOR

FOOD STORAGE COMPARTMENT

The food storage compartment is completely closed and unventilated, which is necessary to maintain the required low temperature for food storage. Consequently, foods having a strong odor or those that absorb odors easily should be covered. Vegetables, salads etc. should be covered to retain their crispness. The coldest positions in the refrigerator are under the cooling fins and at the bottom of the refrigerator. The warmer areas are on the upper door shelves. This should be considered when placing different types of food in the refrigerator.

FROZEN FOOD STORAGE COMPARTMENT

Quick frozen soft fruits and ice cream should be placed in the coldest part of the compartment which is at the bottom of the aluminum liner. Frozen vegetables, may be stored in any part of the compartment.

This compartment is not designed for deep or quick freezing of food. Meat or fish, whether raw or prepared, can be stored in the frozen food storage compartment provided they are precooled first in the refrigerator. They can be stored about three times longer in the frozen food compartment as compared to the fresh food compartment. To prevent food from drying out, keep it in covered dishes, containers, plastic bags or wrapped in aluminum foil.

ICE MAKING

Ice cubes can be made in the ice tray placed in the freezer compartment. The tray should be filled with water to within 1/4" (5 mm) from the top.

For faster ice making, the tray should be placed in direct contact with the bottom of the freezer compartment.

To release the ice cubes, seize the tray with both hands and twist the tray. Cubes not required should be replaced in the tray. Refill the tray with water and replace the tray in the freezer compartment.

Ice will be made more rapidly if the thermostat is set at its highest position. It is a good idea to do this a few hours before the anticipated need for ice, but be sure to turn the thermostat back to normal setting, usually about mid-setting when the ice is formed. Food in the lower compartment may be frozen if the refrigerator is left on "MAX" position.

DEFROSTING

Frost will gradually accumulate on the refrigerating surfaces. It must not be allowed to grow too thick as it acts as an insulator and adversely affects refrigerator performance.

Check the formation of frost regularly every week and when it gets about 3 mm thick, defrost the refrigerator.

Shut off the refrigerator by turning knob "A" to "OFF" position. Empty the refrigerator, leaving the cabinet and freezer doors open. Defrosting time can be reduced by filling the ice tray with hot water and placing it in the freezer compartment.

!CAUTION

DO NOT use a hot air blower. Permanent damage could result from warping the metal or plastic parts. DO NOT use a knife or an ice pick, or other sharp tools to remove frost from the freezer compartment. They can create a leak in the ammonia system.

The defrost water runs from a collector channel to a drip tray/cup at the rear of the refrigerator where it normally evaporates.

If heavy frost built up on the freezer plate and the cooling fins, and a lot of defrost water, move the plastic drain tube in to a watertight bucket or container.

As the frost melts, the water will flow into the container. When all the frost has melted wipe up the excess moisture and empty the accumulated water from the bucket. Replace the drain tube to its original position.

Defrost water in the freezer compartment should be wiped up with a clean cloth.

When all the frost is melted, dry the interior of the refrigerator with a clean cloth. Replace all food and set the thermostat to "MAX" for a few hours. Then reset the thermostat to its normal position.

CLEANING

Cleaning the refrigerator is usually done after it is defrosted or put into storage. To clean the interior liner of the refrigerator, use lukewarm weak soda solution. Use only warm water to clean the finned evaporator, gasket, ice trays and shelves. **NEVER use strong chemicals or abrasives to clean these parts as the protective surfaces will be damaged. It is important to always keep the refrigerator clean.**

SHUT OFF - STORAGE PROCEDURE

To shut off the refrigerator, turn knob "A" to "OFF" position.

If the refrigerator will not be in operation for a period of weeks, it should be emptied, defrosted, cleaned and the doors left ajar. The ice tray should also be dried and kept outside the cabinet.

NOTE: To avoid running down the batteries to the interior light during defrosting and storage periods, use a tape to close the light switch or remove the lamp bulb. The batteries can also be removed from the battery box at the rear of the refrigerator.

!CAUTION

DO NOT store explosive substances in the refrigerator, such as cigarette lighter gas, petrol, ether or the like.

LIGHTING

The refrigerator is provided with a battery power interior light.

The battery box is at the rear of the refrigerator.

Four batteries, type R20 1.5 volts are to be used.

MAINTENANCE & SERVICE

The user should be aware of service that must be done on a regular schedule to keep the refrigerator operating properly. The service should only be performed by a qualified technician who is familiar with LP gas systems and refrigerators.

1. REFRIGERATOR REMOVAL

Before working on the refrigerator, make sure the AC voltage leads are disconnected. Shut off the gas supply. Disconnect the gas supply line at the rear of the refrigerator. Always use a back up wrench when loosening and tightening this connection. Cap the gas supply line and remove the refrigerator.

Replacement is the reverse of removal. Check all connections for gas leaks.

Refer to section INSTALLATION, page 2 and 3.

2. PERIODIC MAINTENANCE

To keep your refrigerator operating efficiently and safely, periodic inspection and cleaning of several components is recommended once or twice a year.

- A. It is important to keep the area at the back of the refrigerator clean. Clean the coils on the back of the refrigerator. Use a soft bristled brush to dust off the coils.

It is important to keep the refrigerator area free from combustible material, gasoline and other flammable vapors or liquids.

NOTE: The following maintenance is required once or twice a year, but should only be done by a qualified serviceman who is familiar with LP gas systems and refrigerators.

- B. Check all connections in the LP gas system (at the back of the refrigerator) for gas leaks. The LP gas supply must be turned on. Apply a noncorrosive bubble solution to all LP gas connections. The appearance of bubbles indicates a leak and should be repaired **immediately** by a QUALIFIED SERVICEMAN WHO IS FAMILIAR WITH GAS SYSTEM AND REFRIGERATORS.

!WARNING

DO NOT use a flame to check for gas leaks.

- C. Check burner flame for proper appearance. The flame should be light blue with no yellow at the tip. See FIG. 4.

Clear blue color
of flame

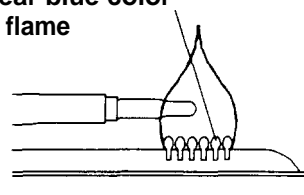
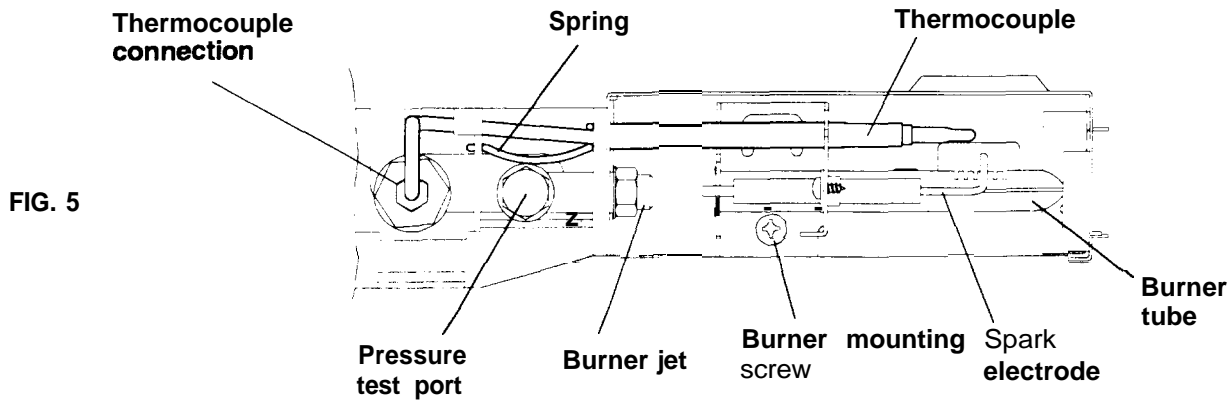

FIG. 4



- D The LP gas pressure should be checked and the main regulator readjusted if pressure is incorrect. The correct operating pressure is 11 inches of water column. The correct place to take the LP gas pressure is at the test port just ahead of the burner jet. (See FIG. 5).
- E. Inspect the flue baffle. It should be reasonably clean and free of soot. Heavy soot formation indicates improper functioning of the burner. The flue and burner both require cleaning in the following manner:
1. Unplug the refrigerator power cord from the 120 volt AC outlet.
 2. Turn the knob "A" to "OFF" position.
 3. Remove cover from the burner housing.
 4. Disconnect the wire from the high voltage electrode.
 5. Remove the burner mounting screw and remove the burner assembly.
 6. Remove the wire and flue baffle from the top of flue tube. Clean the flue from the top using a flue brush. Blowing compressed air into the flue **will not** properly clean soot and scale out of the flue tube. Replace the flue baffle.
 7. Clean burner tube with a brush. Blow out burner with compressed air.
 8. Before removing burner jet, clean burner area of soot and scale that fell out of flue tube. Remove the burner jet. Soak the jet in wood alcohol and blow it out with compressed air. Re-install and tighten burner jet.

!CAUTION

DO NOT use a wire or pin when cleaning the burner jet as damage can occur to the precision opening. This can cause damage to the refrigerator or create a fire hazard.

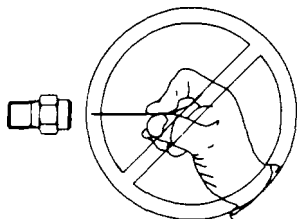

9. Reinstall burner, being careful that the end of the burner fits into the slot on the burner bracket. Check to make sure slots are centered under the flue tube

- and the thermocouple is positioned properly (tip of thermocouple extends over two slots of burner).
10. Be sure to reconnect the wire to high voltage electrode. Check the electrode for proper location and gap. (See FIG. 6).

FIG. 6

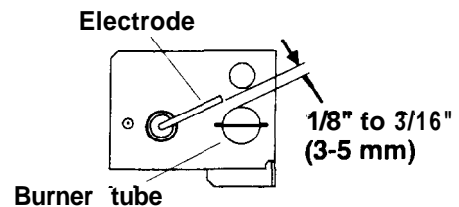

11. The gas fittings on the refrigerator need to be checked for leaks. Turn the knob "A" to position "GAS". Apply a non-corrosive bubble solution to the fitting and observe for leaks. The safety valve will not allow gas pressure to any connections between it and the burner jet. These fittings must be checked before burner is lighted.

!WARNING

The safety shut-off must be manually depressed to allow gas pressure to flow to the burner jet. Be sure to apply the leak check solution before depressing the safety shut-off. DO NOT allow any open flame, sparks, smoking, etc., in the area of the test. DO NOT depress safety shut-off for over 30 seconds.

12. Allow 10 minutes for the LP gas to leave the burner area. Light the burner according to the Operating Instructions, section Gas Operation. Allow burner to run 5 minutes.
13. Connect 120 volt power cord to the outlet.
14. Check LP gas safety shut-off. See page 3.

TROUBLESHOOTING

The Refrigerator Does Not Cool Properly

1. Burner jet clogged. Clean. See Section Maintenance & Service, Item 2. Periodic Maintenance, Paragraph E. Item 1-14.
2. Check level of refrigerator.
3. Restriction in air flow across cooling unit.
4. Heavy frost build-up on evaporator fins. Defrost.
5. Flue baffle not inserted properly in flue tube.
6. Improperly set thermostat. See paragraph on thermostat. In hot weather the setting should be closer to "MAX" than usual.
7. Burner dirty. Clean. See Section Maintenance & Service, Item 2. Periodic Maintenance, Paragraph E. Item 7.
8. LP gas pressure low at burner. Set main regulator so pressure does not drop below 11 inches water column at pressure test port.
9. Burner not located properly under flue tube. Relocate.
10. Burner damaged. Replace.
11. Odors and fumes.
 1. Dislocated burner.
 2. Damaged burner.
 3. Dirty flue tube.

SPARE PARTS

The following list is a list of commonly used parts which should be available, if required, from your Dometic Service Center.

Part No.	Description
200 74 19-21 /7	Jet, no. 58
200 75 03-03/6	Burner, (with electrode)
293 03 79-00/9	Electrode
293 14 96-04/2	Thermocouple
200 75 05-00/7	Cover, (burner)
293 16 57-01/5	Safety valve
200 71 99-04/1	Thermostat
200 74 23-00/3	Piezo igniter
293 26 67-04/7	Baffle
17 37 42-27/1	Heater, 325W, 120V
293 21 06-01/2	Lamp cover
293 25 75-01/8	Door shelf
293 25 76-01/6	Door shelf, 3 pieces
200 74 80-32/6	Knob thermostat
200 74 80-35/9	Knob (On/Off)
293 27 83-01/8	Flap, base front

Contact an authorized service center for parts and repairs as needed.

REFRIGERATOR DIMENSIONS

Overall dimensions in inches and (mm):

Model No. RGE 400

Height 63-15/32 (1612)

Width 23-5/16 (592)

Depth 24-1/2 (623)

Total refrigerator volume: 7.3 cu.ft.

